



AXR



Centrifugal in-line fans for RADON mitigation



Complies with ErP Directive 2009/125/CE and EU Regulation 327/2011
(Classification: FAN)

Radon is a colorless, chemically inert and radioactive odorless gas present in some soils from which it is produced and dispersed in the environment, accumulating in closed rooms where it becomes dangerous. Once accumulated, the Radon can be breathed in and continue the radioactive series within the body, with great damage to health, increasing the risk of developing pulmonary neoplasms. Epidemiological studies published by the World Health Organization (WHO) and the International Agency for Research on Cancer (IARC) have now scientifically established the carcinogenicity of this gas.

The presence of indoor radon is for the most part due to a pressure difference between the external and internal environment; in fact, a cause of the temperature difference, the air pressure inside is smaller, so a gas suction is generated from the outside towards the inside. For good reason, the Radon emitted from the ground is sucked up, it goes up the lower floors and spreads in the rooms of daily use.

In the event that the presence of Radon gas inside a house has been ascertained or is simply presumed, the **most effective intervention** to mitigate its dangerousness and consequently reduce the risks for human health consists in the **creation of a sump** in the basement of the adjacent rooms in order to favor the entry of the Radon gas (which is heavier than air), to then **capture it and convey it through AXR fan at a safe distance from the house.**

In this objective it is always good practice to contact qualified installers for a correct sizing.



FEATURES

- In-line centrifugal fans for residential or commercial application where the presence of the Radon gas is ascertained or presumed.
- Suitable for clean air with max. temperature of 50°C
- Housing in **self-extinguishing V2 technopolymer**
- **Tight sealing**
- Self-cleaning backward curved blades
- **Supplied with connection cable long 1,2 m**
- Statically and dynamically balanced according to ISO 1940
- Single-phase ball bearing motor (230V-50Hz) provided with thermal cut-out, suitable for continuous running
- Class II insulation (no earth connection needed)
- Comply with CEI EN 60335-2-80, EN 60335-2-31, EMC 2014/30/UE and LVD 2014/35/UE

INSTALLATION

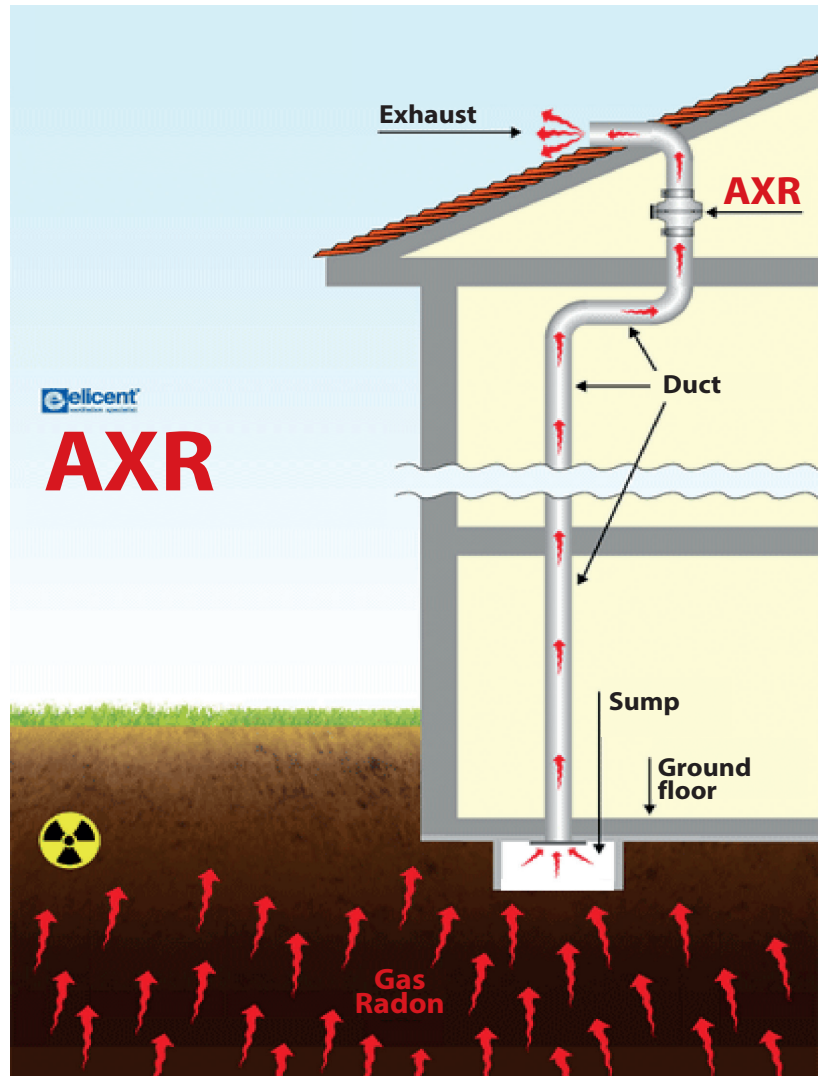

PERFORMANCES

| MODEL | DUCT | AIRFLOW | l/s | PRESSURE MAX | A | W | SOUND PRESSURE (at 3 m) | PROTECTION |
|---------|------|---------|-----|--------------|-------|----|-------------------------|------------|
| | Ø mm | m³/h | | Pa | | | dB (A)* | |
| AXR 100 | 100 | 211 | 59 | 263 | 0,127 | 27 | 36,1 | IPX5 |
| AXR 125 | 125 | 265 | 74 | 251 | 0,129 | 27 | 37,1 | IPX5 |
| AXR 150 | 150 | 415 | 115 | 301 | 0,290 | 65 | 38,1 | IPX5 |
| AXR 160 | 160 | 431 | 120 | 294 | 0,284 | 65 | 39,1 | IPX5 |

* Sound pressure at 3 m with fan ducted.

DIMENSIONS (mm)

| MODEL | A | B | Ø C | Ø D | Kg. |
|---------|-----|----|-----|-----|-----|
| AXR 100 | 238 | 25 | 98 | 212 | 1,5 |
| AXR 125 | 238 | 25 | 123 | 212 | 1,5 |
| AXR 150 | 232 | 28 | 147 | 253 | 2 |
| AXR 160 | 232 | 28 | 157 | 253 | 2 |

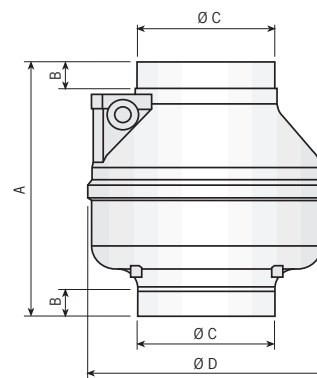

CURVES

